

DUALGO

STATIONARY FILTER UNIT WITH TWO HOSE TUBE ARMS

The DualGo is a stationary welding fume filter with integrated fan and two hose tube arms (EconomyArm). It contains a disposable filter package.

The DualGo has been designed for occasional to regular welding activities (approx. 1 coil of solid wire or 7,5 kg/16.5 lbs of electrodes per workplace per month) and TIG welding.



APPLICATIONS

The DualGo is intended to be used for the following applications:

- MIG-MAG/GMAW welding
- TIG welding
- FCAW welding
- stick/MMAW welding
- grinding
- polishing
- finishing



SPECIFICATIONS

Physical dimensions and properties

Material (housing):	electro-zinc coated steel (according to DIN EN 10152)
• steel grade	• DC01+ZE
• steel grade no.	• 1.0330
Colour	yellow RAL 1004 grey RAL 7011
Weight (net), excl. arm	
Mains cord	not included

Extraction arms

Type	EconomyArm (EA)
Material	hose tube
Length per arm:	
• EA-2	• 2 m
• EA-3	• 3 m
• EA-4	• 4 m
Weight per arm:	
• EA-2	• 11 kg (24.3 lbs)
• EA-3	• 13 kg (28.7 lbs)
• EA-4	• 15 kg (33.1 lbs)

Filters

Pre filter cassette:	
• material	• polyester
• filter surface	• 1 m ² (10.8 ft ²)
• efficiency	• G2 according to EN 779
• washable	• no
HEPA filter cassette:	
• material	• glass fibre
• filter surface	• 26 m ² (280 ft ²)
• efficiency	• HEPA E12 according to EN 1822:2009
• washable	• no

Welding fume class

W3	according to ISO 15012-1:2013
----	-------------------------------

Performance

Fan type	radial
Extraction capacity (incl. extraction arms)	max. 1700 m ³ /h (1000 CFM)
Fan speed	2800 rpm
Noise level (according to ISO 3746)	• 79 dB(A) • with silencer SAS-315

Electrical data

Power consumption	2,2 kW (3 HP)
Available connection voltages	• 400V/3ph/50Hz (435) • 208-230/460V/3ph/60Hz (536) • 575V/3ph/60Hz (636)
Motor design	NEMA
Energy efficiency	IE3 / premium

Ambient and process conditions

Process temperature:	
• min.	• 5°C (41°F)
• nom.	• 20°C (68°F)
• max.	• 70°C (158°F)
Max. relative humidity	90%
Suitable for outdoor use	no
Storage conditions	• 5-45°C (41-113°F) • relative humidity max. 80%

Scope of supply

Stationary filter unit, incl. fan and wall bracket – Extraction arm (pre-assembled; excl. hose tube) – Hose tube – Hose clamp (2) – Rotating flange – Arm swivel ring, incl. rubber collar – Extraction hood – Hood collar with safety mesh – Mounting material – Switch box

Order information

Article no.:	DualGo:
• 0000111462	• DualGo/2+2m (435)
• 0000111463	• DualGo/2+2m (536)
• 0000111464	• DualGo/2+2m (636)
• 0000111482	• DualGo/3+3m (435)
• 0000111483	• DualGo/3+3m (536)
• 0000111484	• DualGo/3+3m (636)
• 0000111494	• DualGo/4+4m (435)
• 0000111495	• DualGo/4+4m (536)
• 0000111496	• DualGo/4+4m (636)
•	•

<ul style="list-style-type: none"> • 0000111500 • 0000111501 • 0000111502 • 0000111506 • 0000111507 • 0000111508 • 0000111512 • 0000111513 • 0000111514 • 	<ul style="list-style-type: none"> • DualGo/2+3m (435) • DualGo/2+3m (536) • DualGo/2+3m (636) • DualGo/2+4m (435) • DualGo/2+4m (536) • DualGo/2+4m (636) • DualGo/3+4m (435) • DualGo/3+4m (536) • DualGo/3+4m (636) •
Number/package	1
Shipping data	
Gross weight (incl. pallet)	
Packing dimensions (incl. pallet)	
Max. number/pallet	
Harmonized Tariff Code	8421.39.2090

DIMENSIONS

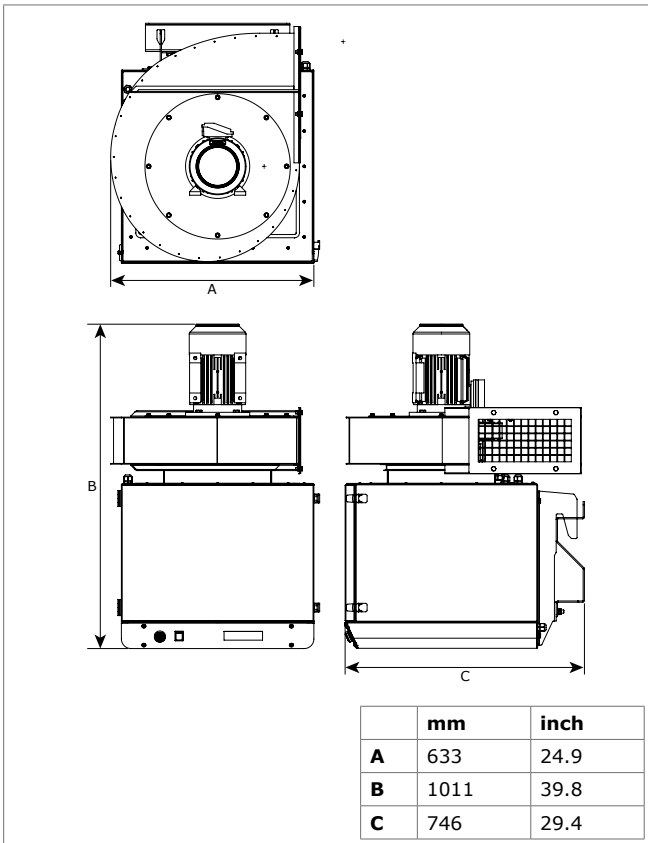

WORKING RANGE

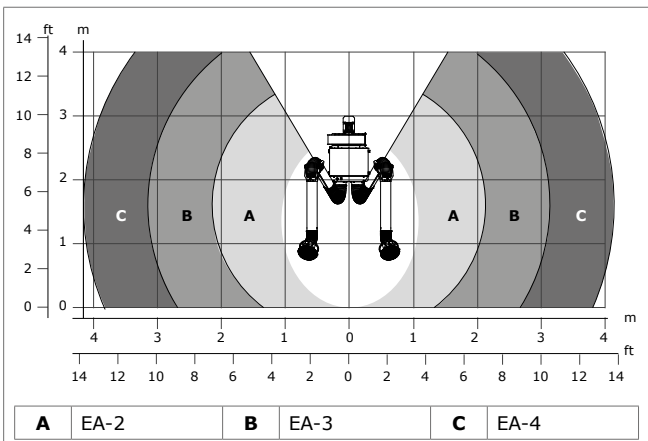

FEATURES & BENEFITS



APPROVALS/CERTIFICATES

	Directive 2011/65/EC (RoHS) valid as of 8 June 2011

Application restrictions

Do **not** use the product for the following applications or in the following circumstances: polishing applications in combination with grinding, welding or any other application that generate sparks (fibres from polishing or abrasive flap disks are highly flammable and pose a high risk of filter fires when exposed to sparks) | aluminium laser cutting | oil mist | heavy oil mist in welding fume | arc-air gouging | extraction of aggressive fumes and gases (e.g. from acids, from alkaline, from soldering paste containing lithium) | extraction of hot gases (more than 70°C/158°F continuously) | grinding aluminum and magnesium | flame spraying | extraction of cement, saw dust, wood dust etc. | sucking cigarettes, cigars, oiled tissues and other burning particles, objects and acids | explosive environments or explosive substances/gases

Product type

DualGo

Article no.

refer to Order information

Product category

stationary filter units

Version

060117/A

Always check the latest version on www.plymovent.com